

28H2P4509A6

电机尺寸
DIMENSIONS:
(UNIT=MM)

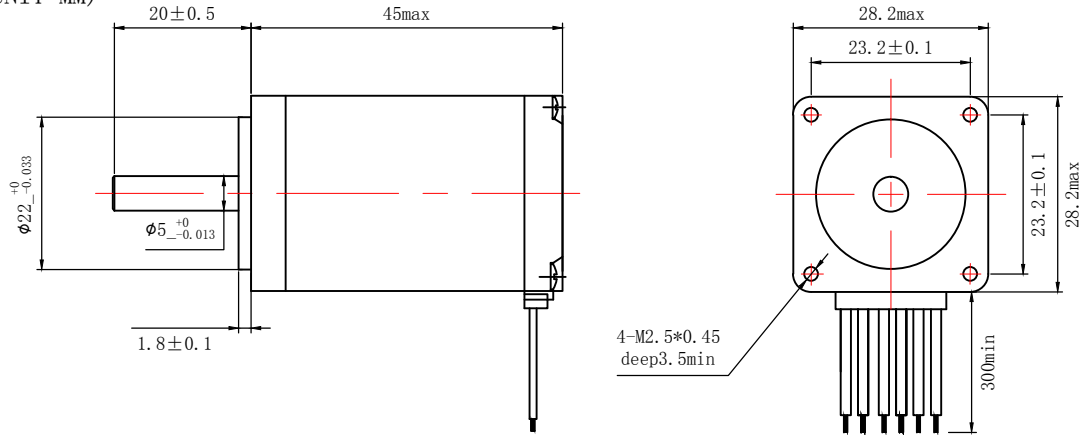

电机接线图
WIRING DIAGRAM:

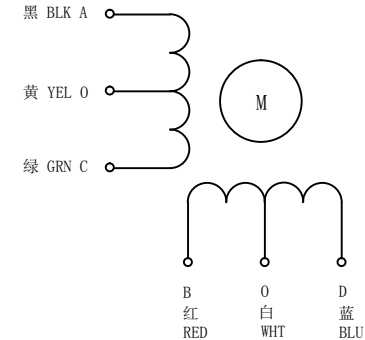

说明
NOTES:

- PLEASE DON'T HOLD MOTOR BY LEAD WIRES.
- PLEASE DON'T PLUG IN/OUT THE MOTOR CONNECTOR WHILE POWER ON.
- PLEASE DON'T DROP, HURL OR DUMP MOTOR AGAINST HARD MATERIAL
MALFUNCTION MAY NOT BE OBSERVED AT EARLY STAGE AFTER SUCH SHOCKS, BUT FOUND LATER. THE MISHANDLING VOIDS OUR WARRANTY.
- DONGGUAN ICAN-TECH WILL NOT BE RESPONSIBLE FOR ANY PATENT DISPUTE OR PROBLEM CAUSED BY ACTUAL APPLICATIONS

驱动连接方式
CONNECTION MODE:

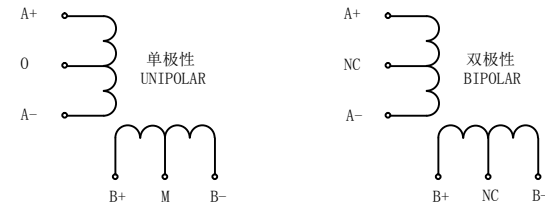

| 电机参数/ELECTRICAL PARAMETER | | 轴径配置/SHAFT DESIGN |
|-----------------------------------|-------------|-------------------|
| 电机型号 MANUFACTURER MODEL | 28H2P4509A6 | |
| 适配步进电机驱动器 MATCHED MOTOR DRIVE | MR2 | |
| 步距角 STEP ANGLE (° /STEP) | 1.8 | |
| 电机电压 RATED VOLTAGE (V) | 3.4 | |
| 电机电流 RATED CURRENT (A/PHASE) | 0.95 | |
| 电机电阻 RESISTANCE (Ω±15%/PHASE) | 3.4 | |
| 电机电感 INDUCTANCE (mH±20%/PHASE) | 1.2 | |
| 电机力矩 HOLDING TORQUE (N.M) | 0.075 | |
| 电机绝缘等级 INSULATION CLASS | B | |

| 连接方式 CONNECTION MODE | 电机电阻 RESISTANCE ohm±15% | 电机电感 INDUCTANCE mh±20% | 电机电流 RATED CURRENT A | 电机电压 RATED VOLTAGE V | 电机力矩 HOLDING TORQUE N-m(oz-in) |
|-------------------------|-------------------------------|------------------------------|----------------------------|----------------------------|--------------------------------------|
| 单极性 UNIPOLAR | 1.7 | 1.2 | 0.95 | 1.7 | 0.065 |
| 双极性 BIPOLAR | 3.4 | 1.2 | 0.95 | 3.4 | 0.075 |

| 制图 DESIGNED | 检图 CHECKED | 校准 APPROVED | 日期 DATE | 比例 SCALE |
|------------------------------------|---------------|--|-----------------------|-------------|
| HUANGTING | MAHUALING | | 2016/03/01 | 1:1 |
| 28H2P4509A6 | | 东莞市一能机电技术有限公司 DONGGUAN ICAN TECHNOLOGY CO., LTD | | |
| 两相步进电机 TWO-PHASE STEPPING MOTOR | | | 版本 EDITION V2.0 | |