

57H2P7842A4-PG

电机尺寸  
DIMENSIONS:  
(UNIT=MM)

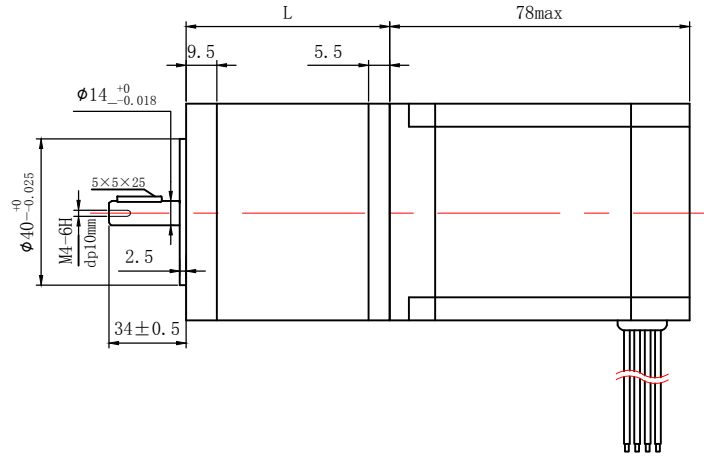

电机接线图  
WIRING DIAGRAM:

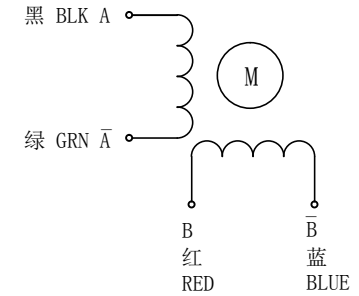
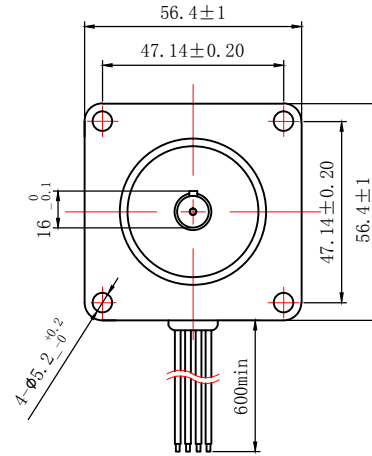

说明  
NOTES:

- PLEASE DON'T HOLD MOTOR BY LEAD WIRES.
- PLEASE DON'T PLUG IN/OUT THE MOTOR CONNECTOR WHILE POWER ON.
- PLEASE DON'T DROP, HURL OR DUMP MOTOR AGAINST HARD MATERIAL.  
MALFUNCTION MAY NOT BE OBSERVED AT EARLY STAGE AFTER SUCH SHOCKS, BUT FOUND LATER. THE MISHANDLING VOIDS OUR WARRANTY.
- DONGGUAN ICAN-TECH WILL NOT BE RESPONSIBLE FOR ANY PATENT DISPUTE OR PROBLEM CAUSED BY ACTUAL APPLICATIONS

技术要求

TECHNICAL REQUIREMENTS:

速比 RATIO	L (M M)	效率 EFFICIENCY	负载 (N. M)	寿命 (h)
1:5/1:10	53	95%	6.0	8000
1:20	70	90%	25	8000

电机参数/ELECTRICAL PARAMETER		轴径配置/SHAFT DESIGN
电机型号 MANUFACTURER MODEL	57H2P7842A4-PG	
适配步进电机驱动器 MATCHED MOTOR DRIVE	MR4/MR5	
步距角 STEP ANGLE (° /STEP)	1.8	
电机电压 RATED VOLTAGE (V)	2.31	
电机电流 RATED CURRENT (A/PHASE)	4.2	
电机电阻 RESISTANCE (Ω±15%/PHASE)	0.55	
电机电感 INDUCTANCE (mH+20%/PHASE)	1.9	
电机力矩 HOLDING TORQUE (N. M)	2.1	
减速机速比 VELOCITY RATIO	1:5/1:10/1:20	

制图 DESIGNED	检图 CHECKED	校准 APPROVED	日期 DATE	比例 SCALE
HUANG TING	MAHUALING		2016/03/01	1:1.8
<b>57H2P7842A4-PG</b>		东莞市一能机电技术有限公司 DONGGUAN ICAN TECHNOLOGY CO., LTD		
步进行星减速电机 PLANETARY STEPPING MOTOR				版本 EDITION V2.0