

42H2P0712A4-G30

电机尺寸
DIMENSIONS:
(UNIT=MM)

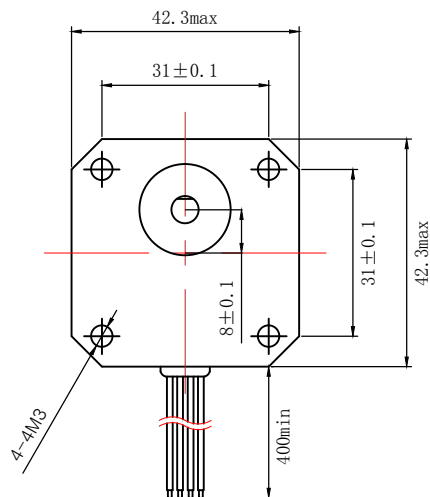

电机接线图
WIRING DIAGRAM:

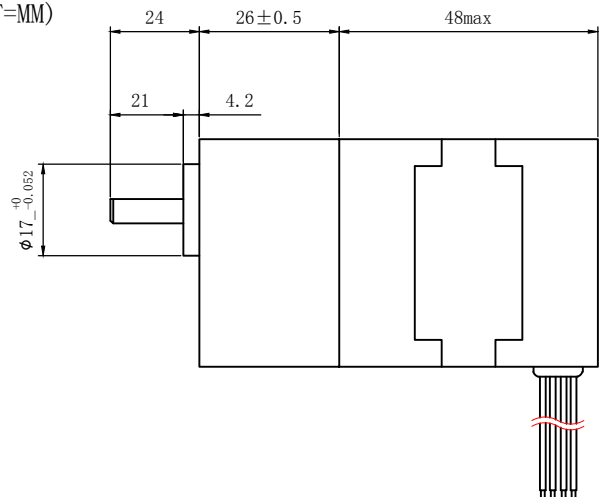
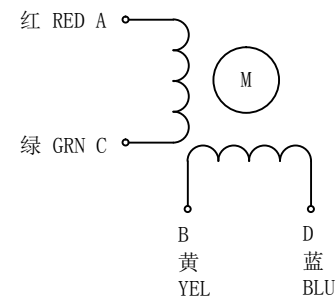

说明
NOTES:

- PLEASE DON'T HOLD MOTOR BY LEAD WIRES.
- PLEASE DON'T PLUG IN/OUT THE MOTOR CONNECTOR WHILE POWER ON.
- PLEASE DON'T DROP, HURL OR DUMP MOTOR AGAINST HARD MATERIAL
MALFUNCTION MAY NOT BE OBSERVED AT EARLY STAGE AFTER SUCH SHOCKS, BUT FOUND LATER. THE MISHANDLING VOIDS OUR WARRANTY.
- DONGGUAN ICAN-TECH WILL NOT BE RESPONSIBLE FOR ANY PATENT DISPUTE OR PROBLEM CAUSED BY ACTUAL APPLICATIONS

驱动连接方式
CONNECTION MODE:

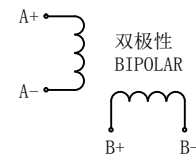

电机参数/ELECTRICAL PARAMETER		轴径配置/SHAFT DESIGNH
电机型号 MANUFACTURER MODEL	42H2P0712A4-G30	
适配步进电机驱动器 MATCHED MOTOR DRIVE	MR2	
步距角 STEP ANGLE (° /STEP)	1.8	
电机电压 RATED VOLTAGE (V)	3.8	
电机电流 RATED CURRENT (A/PHASE)	1.2	
电机电阻 RESISTANCE (Ω±15%/PHASE)	3.2	
电机电感 INDUCTANCE (mH+20%/PHASE)	6.0	
电机力矩 HOLDING TORQUE (N.M)	0.45	
减速机电速比 VELOCITY RATIO	1:30	

制图 DESIGNED	检图 CHECKED	校准 APPROVED	日期 DATE	比例 SCALE
HUANG TING	MAHUALING		2016/03/01	1:1.4
42H2P0712A4-G30		东莞市一能机电技术有限公司 DONGGUAN ICAN TECHNOLOGY CO., LTD		
步进齿轮减速电机 GEARED STEPPING MOTOR			版本 EDITION V2.0	