

85H2P6045A4-G12.5

电机尺寸  
DIMENSIONS:  
(UNIT=MM)

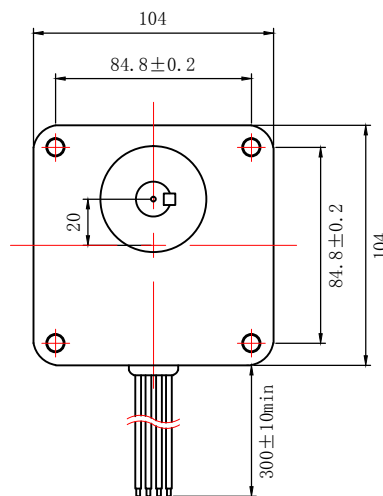

电机接线图  
WIRING DIAGRAM:

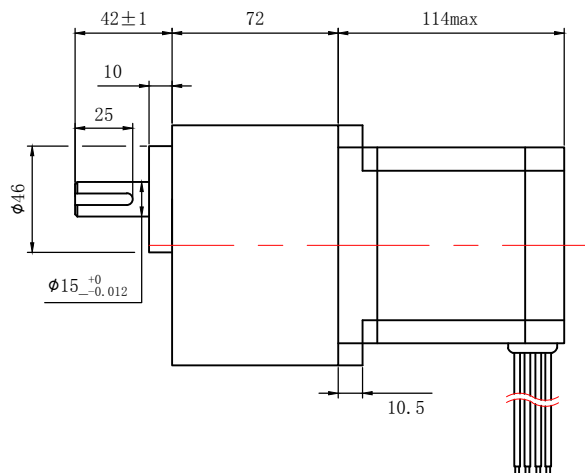
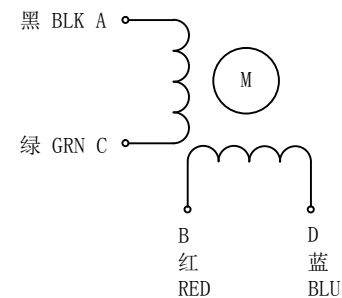

说明  
NOTES:

- PLEASE DON'T HOLD MOTOR BY LEAD WIRES.
- PLEASE DON'T PLUG IN/OUT THE MOTOR CONNECTOR WHILE POWER ON.
- PLEASE DON'T DROP, HURL OR DUMP MOTOR AGAINST HARD MATERIAL  
MALFUNCTION MAY NOT BE OBSERVED AT EARLY STAGE AFTER SUCH SHOCKS, BUT FOUND LATER. THE MISHANDLING VOIDS OUR WARRANTY.
- DONGGUAN ICAN-TECH WILL NOT BE RESPONSIBLE FOR ANY PATENT DISPUTE OR PROBLEM CAUSED BY ACTUAL APPLICATIONS

驱动连接方式  
CONNECTION MODE:

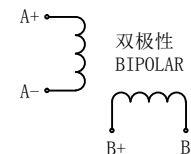

电机参数/ELECTRICAL PARAMETER		轴径配置/SHAFT DESIGNH
电机型号 MANUFACTURER MODEL	85H2P6045A4-G12.5	
适配步进电机驱动器 MATCHED MOTOR DRIVE	MR7/MR7A	
步距角 STEP ANGLE (° /STEP)	1.8	
电机电压 RATED VOLTAGE (V)	3.25	
电机电流 RATED CURRENT (A/PHASE)	4.5	
电机电阻 RESISTANCE (Ω±15%/PHASE)	0.65	
电机电感 INDUCTANCE (mH±20%/PHASE)	4.7	
电机力矩 HOLDING TORQUE (N.M)	4.8	
减速机速比 VELOCITY RATIO	1:12.5	

制图 DESIGNED	检图 CHECKED	校准 APPROVED	日期 DATE	比例 SCALE
HAUNG TING	MAHUALING		2016/03/01	1:3.4
<b>85H2P6045A4-G12.5</b>		东莞市一能机电技术有限公司 DONGGUAN ICAN TECHNOLOGY CO., LTD		
步进齿轮减速电机 GEARED STEPPING MOTOR				版本 EDITION V2.0